

Maintenance / repair of pinch valves

VMC/VT Series DN80 (semi-silo trailer connection)

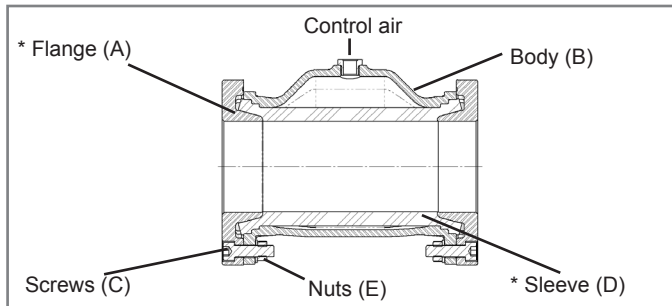

pic. 1



pic. 2



pic. 3



pic. 4



pic. 5



pic. 6



pic. 7



pic. 8

CAUTION: DO NOT USE ANY SHARP TOOLS DURING ASSEMBLY, IT MAY DAMAGE VALVE PARTS!

 <http://www.pinch-valve.com/videos/vt-dn80.html>

AKO Armaturen & Separationstechnik GmbH

D-65468 Trebur-Astheim • Adam-Opel-Str. 5 • Phone: +49 (0) 61 47-9159-0 • Fax: +49 (0) 61 47-9159-59

E-Mail: ako@pinch-valve.com • Internet: www.pinch-valve.com

Removing the old sleeve

Position the valve with screws (C) at the top and hold it tightly from the side. Unscrew the screws (C) and nuts (E) with a ratchet or screw-wrench and fitted tool. To avoid tension on the valve, ensure loosening of the screws (C) and nuts (E) from adjacent sides, then turn the valve through 180 degrees and unscrew the other screws in the same way. Afterwards remove both flanges (A) from the body (B) unit. Now either push the old sleeve (D) out of the body (B) or use a pipe wrench to pull it out. This can be made easier by using the AKO-mounting paste (MP200, for food sector MPL200) in-between the sleeve (D) and body (B). Now clean all single valve parts and check them for damage, particularly the socket end covers (A) for wear, and if necessary replace them.

Installation of the new sleeve

Pic. 1: Lubricate following parts with AKO mounting paste (MP200, for food sector MPL200)

- inside and outside surfaces of sleeve (D),
- cones of flanges (A) and
- inside surface of body (B).

Note: Do not use any grease or oily paste!

For pinch valves that are used in food or pharmaceutical industries, please use exclusively AKO mounting paste MPL200.

Pic. 2: Push sleeve (D) into body (B), so that the sleeve in the body protrudes about 5-6mm upward.

Pic. 3: Position the valve unit with one hand and hold in place; with the other hand, position the flange cone (A) diagonally in the sleeve (D) and push in. If necessary, lubricate the mounting bolts with suitable grease before screwing in.

Pic. 4: Keep the flange (A) pushed on and tighten the mounting bolts and nuts (E) crossways with a ratchet or spanner until the flange (A) is sitting completely flush on the body (B).

Pic. 5+6: Insert 2 standard bolts (C) per flange side (A) into the other two holes and tighten.

Pic. 7: Then replace the mounting bolts on each flange side (A) with standard bolts (C) and tighten.

Pic. 8: **Functional test:** When closing the pinch valve for the first time, a control pressure of 3bar must be applied to enable the sleeve to close fully, showing a lip-shaped form in the sleeve.

* Replacement-/Maintenance parts:

Flange (A), Screws (C), Sleeve (D), Nuts (E)

Assembly tool: AKO mounting paste (MP200, for food sector MPL200)

If necessary, use of 2x mounting screws M10x45 DIN912

Technical details subject to change without notice.