

# Maintenance / repair of pinch valves

VMC Series DN10 to 50, type F, FA, G, M, N, R, RA, T, TA

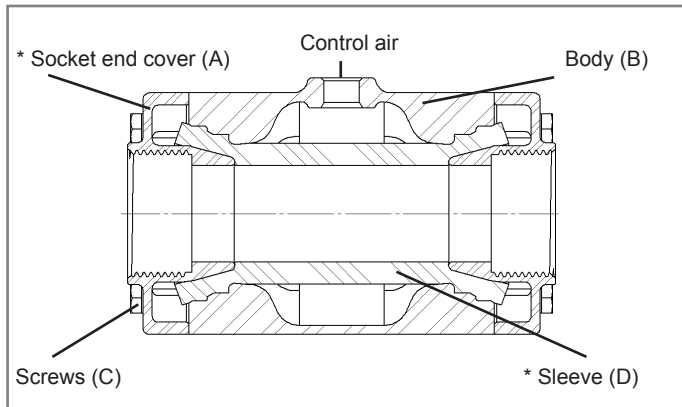

## Removing the old sleeve

Position the valve with screws (C) at the top and hold it tightly from the side. Unscrew the screws (C) with a ratchet and fitted tool (Screw head: Torx 30 or hex SW 10). To avoid tension on the valve, ensure loosening of the screws (C) from adjacent sides, then turn the valve through 180 degrees and unscrew the other screws in the same way. Afterwards remove both socket end covers (A) from the body (B) unit. Now either push the old sleeve (D) out of the body (B) or use a pipe wrench to pull it out.

This can be made easier by using the AKO-mounting paste (MP200, for food sector MPL200) in-between the sleeve (D) and body (B). Now clean all single valve parts and check them for damage, particularly the socket end covers (A) for wear, and if necessary replace them.

## Installation of the new sleeve

**Picture 1:** Push sleeve (D) into body (A), so that the sleeve in the body protrudes about 3-7mm upward. In case it is too hard, please use some AKO mounting paste (MP200, for food sector MPL200) in-between sleeve (D) and body (B). **Caution:** For pinch valves that are used in food or pharmaceutical industries, please use exclusively AKO mounting paste MPL200.

**Picture 2:** Lubricate both inside ends of the sleeve (D) and the cone surface of the socket end cover (A) with a bit of AKO-mounting paste (MP200, for food sector MPL200).

**Picture 3:** Position the valve with one hand and hold it tightly from the side, then place the socket end cover (A) with the other hand by slightly angling one side into the sleeve (D) and push the socket end cover (A) in. Before screwing the screws (C) lubricate them with suitable grease so that the screw connection does not get damaged.

**Picture 4:** Now adjust the screw holes of the socket end cover (A) so they are aligned with the holes of the body (B), then insert the screws (C) with the other hand into the holes. **Caution:** Prior to installation of pinch valve with socket end cover type M, screws must be inserted before putting onto the body.

**Picture 5:** Keep the socket end cover (A) compressed and tighten the screws with the ratchet until the socket end cover (A) is completely flush with the body (B).

**Picture 6:** Then turn the valve through 180 degrees and position it again ready for assembling.

**Picture 7:** Now mount the second socket end cover (A) the same way as described (pictures 3-5). Afterwards check all screws (C) for correct torque.

**Picture 8:** Finished + completed re-sleeve of VMC valve.

### \*Replacement / Maintenance parts:

Socket end cover (A), Screws (C), Sleeve (D)

**Assembly tool:** AKO mounting paste (MP200, for food sector MPL200)



picture 1



picture 2



picture 3

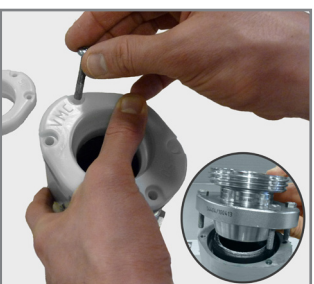

picture 4



picture 5



picture 6



picture 7



picture 8

 <http://www.pinch-valve.com/videos.html>

Technical details subject to change without notice

**AKO Armaturen & Separationstechnik GmbH**

D-65468 Trebur-Astheim • Adam-Opel-Str. 5 • Phone: +49 (0) 61 47-9159-0 • Fax: +49 (0) 61 47-9159-59

E-Mail: [ako@pinch-valve.com](mailto:ako@pinch-valve.com) • Internet: [www.pinch-valve.com](http://www.pinch-valve.com)