

# Maintenance / repair of pinch valves

## Series VF DN 100 to 300 (flange type)

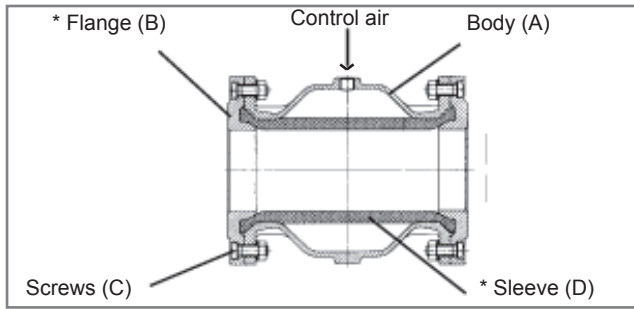

### Removing the old sleeve

Loose bolts (C), take off flanges (B). Pull out old sleeve (D) by using a pipe wrench. If helpful, lubricate AKO mounting paste (MP200, for food sector MPL200) between rubber and internal body surface.

Clean all valve parts and inspect for wear.

### Installation of the new sleeve

**Picture 1:** Lubricate following parts with AKO mounting paste (MP200, for food sector MPL200)

- inside and outside surfaces of sleeve (D),
- cones of flanges (B) and
- inside surface of body (neck area).

**Note:** Do not use any grease or oily paste!

**Picture 2:** Push sleeve (D) into body (A) until it is centred.

**Picture 3:** Assemble flange (B) onto body and fix it with 2 or 4 mounting bolts (C), washer and nuts. Tighten them counter clockwise until flange cone touches the sleeve.

**Picture 4:** Put opposite side of flange (B) into sleeve (D) and tighten second bolt (C), washer and nut until it touches the sleeve.

**Picture 5:** Push mounting pipe into the valve (5/6 length of the sleeve). Put 3 bar air through the air inlet to pressurize the sleeve.

**Picture 6+7:** Use a spanner and push the sleeve behind the cone from the flange (B). Tighten mounting bolts (30Nm) from second flange (B) and assemble completely with the remaining bolts (C). Bolts have to be tightened. Assemble counter flange as described in picture 5, 6+7. Release control air and remove mounting pipe. Make sure that all mounting bolts have been replaced by assembling bolts (C). Verify bolts are tight.

**Picture 8:** Put mounting wood into valve assembly, with the small part facing to the air inlet. Pressurise valve with 3 bar and keep the wood in stable position. Sleeve must close in "lip-shape" position viewing to air inlet. Alternatively assembly: Valve can be assembled under a mechanical press.

**Note:** Do not use any sharp tools during assembly, it may damaged valve parts!



Picture 1



Picture 2



Picture 3



Picture 4



Picture 5



Picture 6



Picture 7



Picture 8

**\*Replacement-/ Maintenance parts:** Sleeve (D) and flanges (B).

**Assembly tool:** AKO mounting set (i.e. W125) consists of mounting paste (MP200, for food sector MPL200), mounting pipe, assembly board, assembling screws, nuts and bolts.

<http://www.pinch-valve.com/videos.html>

Technical details subject to change without notice

**AKO Armaturen & Separationstechnik GmbH**

D-65468 Trebur-Astheim • Adam-Opel-Str. 5 • Phone: +49 (0) 61 47-9159-0 • Fax: +49 (0) 61 47-9159-59

E-Mail: [ako@pinch-valve.com](mailto:ako@pinch-valve.com) • Internet: [www.pinch-valve.com](http://www.pinch-valve.com)