

Maintenance / Repair Instructions for Pinch Valves

Series OV type M (handwheel)



DN 15-50

Step 1a:

Remove the sleeve fixing screw (18) from the lower body half (03).

DN 15-250

Step 1b:

Unscrew the body half screws (16) of the body halves (02-03). Remove the handwheel (14) by loosening the lock nut. Then separate the two body halves (02-03).

Step 2:

Unscrew the sleeve fixing screws (17) and remove the sleeve (04).

Step 3:

Replace the sleeve (04) and mount the sleeve fixing screws (17).

Step 4:

Position the sleeve (04) within the valve body (02-03), lock body half screws (16) and secure the handwheel (14).

PERFORMANCE TEST:

Operate the valve several times and check for easy running closing and opening.

Code	Description	Quantity DN15-50	Quantity DN 65-250
02	Upper body half	1	1
03	Lower body half	1	1
04	Sleeve	1	1
14	Handwheel	1	1
16	Body half screws	4	4
17	Sleeve fixing screws	2	4
18	Lower Sleeve fixing screw	1	0

DN 15 - 250mm

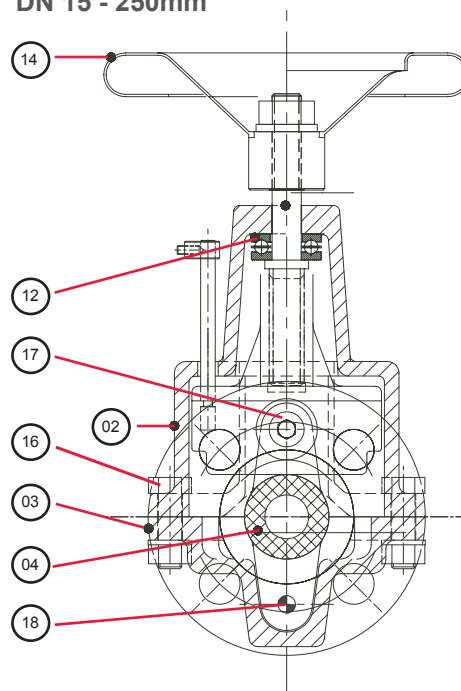

DN 65 - 250mm

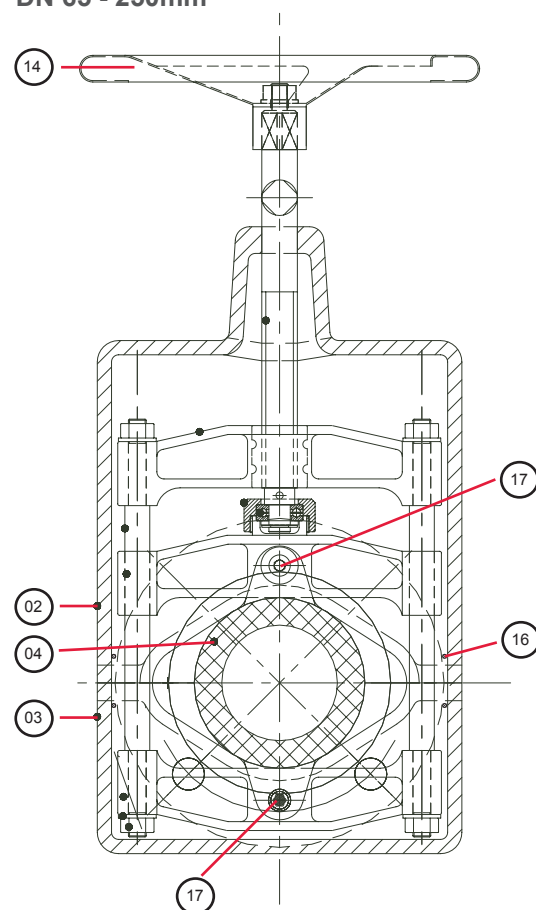

<http://www.pinch-valve.com/videos/ov-dn15-50-type-m.html>
<http://www.pinch-valve.com/videos/ov-dn65-250-type-m.html>

Technical details subject to change without notice.

AKO Armaturen & Separationstechnik GmbH

D-65468 Trebur-Astheim • Adam-Opel-Str. 5 • Phone: +49 (0) 61 47-9159-0 • Fax: +49 (0) 61 47-9159-59
 E-Mail: ako@ako-armaturen.de • Web: www.pinch-valve.com